



## INSTALLATION & MAINTENANCE INSTRUCTIONS | VINYL CLICK PLANKS GRANDE AND VENTI WITH UNILIN LOCKING SYSTEM

**PLEASE READ ALL INSTRUCTIONS CAREFULLY, BEFORE YOU BEGIN INSTALLATION.  
IMPROPER INSTALLATION WILL VOID WARRANTY. FOR ALL INSTALLATION CONDITIONS AND INFORMATION NOT COVERED SPECIFICALLY UNDER THESE INSTRUCTIONS, OR DEFECTIVE MATERIAL, CONTACT MANUFACTURER.**

ALWAYS CHECK THE MANUFACTURER WEBSITE FOR THE LATEST INSTALLATION, MAINTENANCE, AND WARRANTY INFORMATION. READ AND FOLLOW ALL MANUFACTURER INSTRUCTIONS.

### **PLEASE NOTE: FLOATING FLOORS ARE DESIGNED TO EXPAND AND CONTRACT MONOLITHICALLY WITHOUT RESTRICTION.**

SPECIAL ATTENTION NEEDS TO BE GIVEN TO (BUT NOT LIMITED TO):

- AVOID EXCESSIVE HEAT, SUCH AS SUN ROOMS AND AREAS WITH EXTENDED DIRECT SUNLIGHT. EXCESSIVE HEAT CAN CAUSE UNEVEN EXPANSION AND CONTRACTION AND RESULT IN FLOORS BUCKLING. WINDOW COVERINGS CAN BE INSTALLED TO REDUCE EXCESSIVE HEAT.
- DO NOT APPLY BASEBOARD TOO TIGHT TO THE FLOORING OR NAIL THROUGH THE FLOORING, RESULTING IN RESTRICTED MOVEMENT.
- DO NOT RESTRICT MOVEMENT BY INSTALLING CABINETS, ISLANDS, OR OTHER HEAVY OBJECTS ON TOP OF THE FLOORING. HEAVY OBJECTS SUCH AS POOL TABLES AND REFRIGERATORS ARE ACCEPTABLE AS LONG AS THEY DO NOT EXCEED 300 PSI ONTO THE FLOOR.
- ALL SUBFLOORS MUST BE SMOOTH AND FLAT, VOID OF WAXES OR OTHER CONTAMINATES THAT MIGHT ALLOW THE FLOORING TO STICK TO THE SUBFLOOR SURFACE, RESTRICTING MOVEMENT.
- ALWAYS ALLOW PROPER EXPANSION SPACE. AN EXPANSION GAP MUST BE PROVIDED, CONTINUOUSLY, AT ALL VERTICAL SURFACES, ALLOWING MATERIAL TO EXPAND AND CONTRACT WITH NO RESTRICTION.
- FLOORS THAT ARE RESTRICTED FROM FREELY EXPANDING AND CONTRACTING ARE SUBJECT TO BUCKLES AND GAPS. BUCKLING AND GAPPING DUE TO RESTRICTED MOVEMENT IS NOT COVERED UNDER WARRANTY.

**IMPORTANT:** THIS PRODUCT MAY COME WITH AN ATTACHED CUSHION, NO ADDITIONAL CUSHION IS REQUIRED. BUT FOR A SPECIFIC AREA MOISTURE BARRIER OVER CONCRETE - POLYETHYLENE PLASTIC SHEETING BETWEEN 4 AND 10MILS IS REQUIRED AND MUST BE INSTALLED SMOOTHLY.

### **GENERAL GUIDELINES**

ALWAYS FOLLOW THE MOST CURRENT INSTALLATION INSTRUCTIONS. FOR THE MOST CURRENT INSTRUCTIONS PLEASE SEE THE MANUFACTURER'S WEBSITE. ALWAYS READ THE COMPLETE INSTALLATION INSTRUCTIONS PRIOR TO INSTALLATION. ALWAYS FOLLOW ALL LOCAL AND FEDERAL BUILDING CODES. ALWAYS FOLLOW ALL OSHA REGULATIONS FOR SAFETY.

ALTHOUGH THIS PRODUCT IS WATERPROOF, IT IS NOT A MOISTURE BARRIER.

### **INSTALLATION TOOLS REQUIRED**

- SPACERS/SHIMS
- RUBBER Mallet
- HAND SAW, CIRCULAR SAW, JIG SAW
- UTILITY KNIFE
- TAPE MEASURE
- PENCIL
- STRING LINE
- SQUARE, RULER
- PULL/PRY BAR

### **TABLE OF CONTENTS**

- |                                   |   |                               |
|-----------------------------------|---|-------------------------------|
| 1) PRE-INSTALLATION CHECKLIST     | 7) SUBFLOOR CONSTRUCTION REQUIREMENTS   | 11) TRIM                      |
| 2) INSTALLER RESPONSIBILITIES     | 8) RADIANT HEATED FLOORS                | 12) INSTALLING ON STAIRS      |
| 3) SUITABILITY OF PRODUCT         | 9) LAYOUT                               | 13) INSTALLATION INSTRUCTIONS |
| 4) SITE CONDITION REQUIREMENTS    | 10) EXPANSION SPACE AND TRANSITION TRIM | 14) POST INSTALLATION         |
| 5) ACCLIMATION REQUIREMENTS       |   | 15) MAINTENANCE               |
| 6) SUBFLOOR FLATNESS REQUIREMENTS |   |                               |

## 1) PRE-INSTALLATION CHECKLIST

**NORMAL ROOM CONDITIONS (NRC):** NORMAL ROOM CONDITIONS ARE DEFINED AS; AMBIENT AIR TEMPERATURE BETWEEN 64-84 DEGREES FAHRENHEIT; SURFACE TEMPERATURE BETWEEN 64-84 DEGREES FAHRENHEIT; AMBIENT RH (RELATIVE HUMIDITY) BETWEEN 25%-60%. FLOORING SHOULD BE THE LAST MATERIAL INSTALLED ON A PROJECT. MAKE SURE ALL PAINTING AND DRYWALL IS DONE, DOORS AND WINDOWS ARE INSTALLED, AND HVAC SYSTEM IS INSTALLED AND OPERATING. BEFORE INSTALLING, THE CARTONS SHOULD BE OPENED AND PLANKS PLACED UNDER SAME NRC (BETWEEN 64-84 DEGREES FAHRENHEIT) FOR AT LEAST 48 HOURS.

**ACCLIMATION:** FLOORING PRODUCTS ARE DESIGNED TO PERFORM IN NORMAL ROOM CONDITIONS (NRC). AMBIENT TEMPERATURE AND SURFACE TEMPERATURE MUST BE BETWEEN 64-84 DEGREES FAHRENHEIT, AMBIENT RELATIVE HUMIDITY (RH) MUST BE BETWEEN 25%-60%. FLOORING PRODUCTS MUST ACHIEVE AND MAINTAIN NRC PRIOR TO, DURING, AND AFTER INSTALLATION. TEMPERATURE READINGS MUST BE TAKEN AND DOCUMENTED, INCLUDING AMBIENT ROOM TEMPERATURE AND SURFACE TEMPERATURE. ACCLIMATE CARTONS LAYING FLAT, NOT ON END OR ON SIDE, STACKED NO MORE THAN 5 CARTONS HIGH. AVOID STORING FLOORING IN DIRECT SUNLIGHT. DO NOT STORE ON RADIANT IN-FLOOR HEATED AREAS.

### **SUBFLOOR MOISTURE CONCRETE SUBSTRATES:**

NOTE: ALL INSTALLATIONS OVER CONCRETE REQUIRE EITHER A MOISTURE MITIGATION SEALER TO BE APPLIED THAT PROTECTS UP TO 96% RH OR 18 POUNDS PER 1000 SQ FT LIKE SIKA MB EZ RAPID OR A 6MIL VISQUEEN VAPOR BARRIER TO PROTECT FROM HYDROSTATIC PRESSURE

MOISTURE LEVELS IN CONCRETE SUBSTRATES MUST BE NO HIGHER THAN 55% RELATIVE HUMIDITY. FOR LEVELS HIGHER THAN APPROVED LEVELS, MOISTURE MITIGATE WITH A PRODUCT DESIGNED TO REDUCE MOISTURE LEVEL TO ACCEPTABLE LEVEL. SUBFLOOR PH MUST BE BETWEEN 5-9 ON A PH SCALE. IT IS DIFFICULT TO MEASURE GYPSUM SUBSTRATES FOR MOISTURE. ALTHOUGH RELATIVE HUMIDITY PROBES (ASTM F2170) ARE THE RECOMMENDED METHOD OF TESTING, THEY ARE NOT PRACTICAL DUE TO THE NUMBER OF TESTS REQUIRED AND OFTEN THE THICKNESS OF THE GYPSUM. A PROFESSIONAL ELECTRONIC MOISTURE INDICATOR (PROTIMETER AQUANT RECOMMENDED) CAN BE USED TO INDICATE IF THE SUBSTRATE IS DRY ENOUGH TO RECEIVE FLOOR COVERING.

**NEW AND EXISTING CONCRETE SUBFLOORS SHOULD MEET THE GUIDELINES OF THE LATEST EDITION OF ACI 302 AND ASTM F 710, "STANDARD PRACTICE FOR PREPARING CONCRETE FLOORS TO RECEIVE RESILIENT FLOORING" AVAILABLE FROM THE AMERICAN SOCIETY FOR TESTING AND MATERIALS, 100 BARR HARBOR DRIVE, WEST CONSHOHOCKEN, PA 19428; 610-832-9585; [HTTP://WWW.ASTM.ORG](http://www.astm.org).**

- FLOORS SHALL BE SMOOTH, PERMANENTLY DRY, CLEAN, AND FREE ALL FOREIGN MATERIAL SUCH AS DUST, WAX, SOLVENTS, PAINT, GREASE, OILS, AND OLD ADHESIVE RESIDUE. THE SURFACE MUST BE HARD AND DENSE, AND FREE FROM POWDER OR FLAKING.
- IF THE ADHESIVE RESIDUE IS ASPHALT-BASED (CUT-BACK), OR ANY OTHER TYPE OF ADHESIVE IS PRESENT, IT MUST BE REMOVED BY INDUSTRY ACCEPTED METHODS SUCH AS MECHANICAL REMOVAL OR WET SCRAPING.
- ADHESIVE REMOVAL THROUGH THE USE OF SOLVENTS OR CITRUS ADHESIVE REMOVERS IS NOT RECOMMENDED. SOLVENT RESIDUE LEFT IN OR ON THE SUBFLOOR MAY AFFECT THE NEW ADHESIVE AND FLOOR COVERING.

WARNING! DO NOT SAND, DRY SWEEP, DRY SCRAPE, DRILL, SAW, BEAD BLAST OR MECHANICALLY CHIP OR PULVERISE EXISTING RESILIENT FLOORING, BACKING, LINING FELT, ASPHALTIC "CUT BACK" ADHESIVES OR OTHER ADHESIVES.

THESE PRODUCTS MAY CONTAIN EITHER ASBESTOS FIBERS AND/OR CRYSTALLINE SILICA. AVOID CREATING DUST. INHALATION OF SUCH DUST IS A CANCER AND RESPIRATORY TRACT HAZARD. SMOKING BY INDIVIDUALS EXPOSED TO ASBESTOS FIBERS GREATLY INCREASES THE RISK OF SERIOUS BODILY HARM. UNLESS POSITIVELY CERTAIN THAT THE PRODUCT IS A NON-ASBESTOS-CONTAINING MATERIAL, YOU MUST PRESUME IT CONTAINS ASBESTOS. REGULATIONS MAY REQUIRE THAT THE MATERIAL BE TESTED TO DETERMINE ASBESTOS CONTENT AND MAY GOVERN THE REMOVAL AND DISPOSAL OF MATERIAL. SEE CURRENT EDITION OF THE RESILIENT FLOOR COVERING INSTITUTE (RFCI) PUBLICATION RECOMMENDED WORK PRACTICES FOR REMOVAL OF RESILIENT FLOOR COVERINGS FOR DETAILED INFORMATION AND INSTRUCTIONS ON REMOVING ALL RESILIENT COVERING STRUCTURES. FOR CURRENT INFORMATION GO TO [WWW.RFCI.COM](http://www.rfci.com).

- CONCRETE SLABS MUST BE DRY WITH NO VISIBLE MOISTURE.
- MOISTURE TESTING - MAXIMUM MOISTURE LEVEL PER ASTM 1869 CACL IS 8 LBS.
- DO NOT INSTALL OVER CONCRETE WITH A HISTORY OF HIGH MOISTURE OR HYDROSTATIC CONDITIONS. EXCESSIVE MOISTURE IN THE SUBFLOOR COULD PROMOTE MOLD, MILDEW, AND OTHER MOISTURE RELATED ISSUES LIKE THE TRAPPING OF MOISTURE EMISSIONS UNDER THE FLOORING, WHICH MAY CONTRIBUTE TO AN

UNHEALTHY INDOOR ENVIRONMENT. TRUETOUGH DOES NOT WARRANT NOR IS RESPONSIBLE FOR DAMAGE TO FLOOR COVERING DUE TO MOISTURE RELATED ISSUES.

- THE FINAL RESPONSIBILITY FOR DETERMINING IF THE CONCRETE IS DRY ENOUGH FOR INSTALLATION OF THE FLOORING LIES WITH THE FLOOR COVERING INSTALLER.

**SUBFLOOR MOISTURE WOOD SUBSTRATES:** MOISTURE LEVELS IN WOOD UNDERLAYMENT MUST NOT EXCEED 8% MOISTURE DETERMINED BY A PROFESSIONAL ELECTRONIC PIN METER (EXAMPLE: PROTIMETER SURVEYMASTER). SUBFLOOR PH MUST BE BETWEEN 5-9 ON A PH SCALE.

**SUBFLOOR CONSTRUCTION:** SUBFLOORS MUST BE CLEAN, DRY, AND FREE OF ANY MATERIALS THAT MIGHT INTERFERE WITH UNRESTRICTED MOVEMENT. SUBFLOORS MUST BE SOUNDLY CONSTRUCTED TO ELIMINATE VERTICAL MOVEMENT. SUBFLOORS MUST BE FLAT, NO MORE THAN 5/64" UNDULATION IN 6.56 LINEAR FEET. SUBFLOORS MUST MEET ALL FEDERAL AND LOCAL BUILDING CODES. PATCH SUBFLOOR DEPRESSIONS USING A PORTLAND BASED PATCH, GRIND DOWN HIGH SPOTS FOLLOWING ACCEPTABLE INSTALLATION STANDARDS. **\*NOTE: FOR WOOD SUBSTRATES ENSURE THAT THERE IS A MINIMUM OF 18" BETWEEN THE SUBFLOOR AND THE GROUND, THE CRAWL SPACE IS VENTILATED, AND THERE IS A MINIMUM 6MIL POLY SHEETING INSTALLED OVER THE ENTIRE GROUND SURFACE OVERLAPPED AND TAPED.**

**APPROVED SUBSTRATES:** APPROVED SUBSTRATES INCLUDE: PROPERLY PREPARED CONCRETE AND CEMENT LEVELING COMPOUNDS (MINIMUM 3500 PSI), PROPERLY PREPARED GYPSUM (MINIMUM 3500 PSI), AND UNDERLAYMENT GRADE PLYWOOD/OSB/OFB BOARD. **\*NOTE: CONCRETE SUBSTRATES MUST BE PROPERLY CURED AND MEET MOISTURE REQUIREMENTS. ALL CONCRETE SUBSTRATES ON OR BELOW GRADE ARE REQUIRED TO HAVE AN APPROVED POLY FILM MOISTURE BARRIER WITH MINIMUM 6MIL THICKNESS PROPERLY INSTALLED.**

**RADIANT HEATED FLOORING:** FLOORING IS ONLY APPROVED OVER HYDRONIC (WATER) RADIANT HEAT SYSTEMS. RADIANT HEATED FLOORS SHOULD NEVER EXCEED 85 DEGREES FAHRENHEIT. THE HEATING COMPONENTS MUST HAVE A MINIMUM OF 3/8" SEPARATION FROM THE PRODUCT.

**ADHESIVE RESIDUE:** NEVER INSTALL OVER ADHESIVE RESIDUE. ALL RESIDUE MUST BE COMPLETELY REMOVED OR PROPERLY ENCAPSULATED.

**INTERIOR ONLY:** THIS PRODUCT IS DESIGNED FOR INTERIOR CLIMATE CONTROLLED AREAS ONLY.

**VISUAL INSPECTION:** ALL FLOORING MUST BE INSPECTED, IN PROPER LIGHTING, PRIOR TO INSTALLATION. INSTALLED MATERIAL WITH VISIBLE DEFECTS IS NOT COVERED UNDER THE FLOORING WARRANTY.

**ATTACHED PAD:** IF PRODUCT COMES WITH AN ATTACHED PAD, AN ADDITIONAL CUSHION BENEATH THE FLOORING IS NOT REQUIRED. BUT FOR SPECIFIC AREA, MOISTURE BARRIER OVER THE CONCRETE - POLYETHYLENE PLASTIC SHEETING BETWEEN 4 AND 10MILS IS REQUIRED AND THE SHEETING MUST BE SMOOTHLY INSTALLED.

**PRODUCT DIRECTION:** FOR BEST VISUAL RESULTS INSTALL FLOORING IN THE SAME DIRECTION OF DIRECT SUNLIGHT. **BUT THE PREMISE IS THAT WHEN INSTALLING, THE LENGTH SIDE OF THE PLANK MUST BE PARALLEL TO THE LENGTH OF THE ROOM OR THE AREA.** USE OF SUITABLE WINDOW COVERINGS DURING THE TIMES OF MOST DIRECT SUNLIGHT IS STRONGLY RECOMMENDED. ALWAYS WORK OUT OF 3-5 CARTONS MIXING PRODUCTS FROM SEVERAL BOXES. ALWAYS DRY LAY PRIOR TO FINAL INSTALLATION TO ENSURE BEST VISUAL RESULTS.

**CHAIR PADS AND LEG PROTECTORS:** **CHAIR PADS ARE REQUIRED UNDER ROLLER CASTORS AND LEG PROTECTORS,** A MINIMUM OF 1.5" DIAMETER, ARE REQUIRED UNDER CHAIR LEGS.

**FLOOR PROTECTION:** AFTER INSTALLATION FLOORS MUST BE PROTECTED FROM TRADE AND OTHER DAMAGE BY A FLOOR PROTECTION DESIGNED FOR THIS PURPOSE.

## **2) INSTALLER RESPONSIBILITIES**

IT IS THE FLOOR COVERING INSTALLERS' RESPONSIBILITY TO:

- MAKE SURE THE LATEST INSTALLATION INSTRUCTIONS ARE FOLLOWED. FOR THE MOST CURRENT INSTRUCTIONS GO TO THE MANUFACTURER'S WEBSITE.
- MAKE SURE THE PRODUCT IS SUITABLE FOR ITS INTENDED USE.
- VISUALLY INSPECT ALL MATERIAL AND REMOVE ANY VISIBLY DEFECTIVE MATERIAL. VISIBLY DEFECTIVE MATERIAL INSTALLED WILL NOT BE COVERED UNDER WARRANTY.
- STOP ANY PROJECT THAT DOES NOT MEET INSTALLATION GUIDELINES AND CONTACT THE FLOORING RETAILER IT WAS PURCHASED FROM.

- WORK OUT OF SEVERAL BOXES MIXING PRODUCT FOR VISUAL APPEARANCE. DRY FIT PRIOR TO INSTALLATION IS THE RECOMMENDED METHOD.

### 3) SUITABILITY OF PRODUCT

THIS PRODUCT IS APPROVED FOR CLIMATE CONTROLLED INDOOR APPLICATIONS ONLY.

#### APPROVED FOR USE IN:

- RESIDENTIAL APPLICATIONS (EXCLUSIONS: HEAVY ROLLING TRAFFIC SUCH AS HOSPITAL BEDS OR ELECTRIC WHEELCHAIRS)
- MULTI-FAMILY APPLICATIONS (EXCLUSIONS: HEAVY ROLLING TRAFFIC SUCH AS HOSPITAL BEDS OR ELECTRIC WHEELCHAIRS)
- LIGHT COMMERCIAL APPLICATIONS: LIGHT COMMERCIAL IS DEFINED AS LIGHT TRAFFIC COMMERCIAL AREAS SUCH AS BUSINESS OFFICES AND BOUTIQUE SHOPS (EXCLUSIONS: HEAVY ROLLING TRAFFIC SUCH AS HOSPITAL BEDS OR ELECTRIC WHEELCHAIRS)

#### NOT APPROVED FOR USE IN:

- AREAS OF HEAVY ROLLING LOADS (SUCH AS: HOSPITAL BEDS, ELECTRIC WHEELCHAIRS)
- HEAVIER TRAFFIC AREAS, ENTRY FOYERS, OR ANY AREA WHERE FOOD IS PREPARED OR OBJECTS ARE ROLLED OR DRAGGED AROUND
- INDUSTRIAL APPLICATIONS

**IMPORTANT:** PLEASE READ WARRANTY FOR A MORE COMPLETE DEFINITION OF ACCEPTABLE USE.

### 4) SITE CONDITION REQUIREMENTS (NRC)

#### NORMAL ROOM CONDITIONS:

NORMAL ROOM CONDITIONS (NRC) MUST BE MAINTAINED PRIOR TO, DURING, AND AFTER INSTALLATION.

THE NRC ARE DEFINED AS:

- AMBIENT AIR TEMPERATURE BETWEEN 64-84 DEGREES FAHRENHEIT
- SURFACE TEMPERATURE BETWEEN 64-84 DEGREES FAHRENHEIT
- AMBIENT RH (RELATIVE HUMIDITY) BETWEEN 25%-60%
- SUBSTRATE MUST BE DRY: CONCRETE - LESS THAN 55% RH (RELATIVE HUMIDITY), WOOD LESS THAN 8% MOISTURE
- PH LEVELS BETWEEN 5-9

ALL FLOORING PRODUCTS ARE REQUIRED TO ACHIEVE NRC PRIOR TO INSTALLATION.

### 5) ACCLIMATION REQUIREMENTS

#### ALL PRODUCTS MUST ACCLIMATE TO THE ROOM CONDITIONS IN WHICH THEY ARE BEING INSTALLED.

FLOORING PRODUCTS (INCLUDING ADHESIVE & TRIM) ARE DESIGNED TO PERFORM IN NORMAL ROOM CONDITIONS (NRC). FLOORING PRODUCTS MUST ACHIEVE AND MAINTAIN NRC 24 HOURS PRIOR TO, DURING AND AFTER INSTALLATION. TEMPERATURE AND RELATIVE HUMIDITY READINGS MUST BE TAKEN AND DOCUMENTED, INCLUDING AMBIENT ROOM TEMPERATURE AND SURFACE TEMPERATURE.

ACCLIMATE CARTONS LAYING FLAT, NOT ON END OR ON SIDE, STACKED NO MORE THAN 5 CARTONS HIGH. ALLOW AIR MOVEMENT BETWEEN BOXES. AVOID STORING FLOORING IN DIRECT SUNLIGHT. DO NOT STORE ON OPERATIONAL RADIANT IN-FLOOR HEATED AREAS. IT IS CRITICAL TO TAKE A SURFACE TEMPERATURE READING OF THE VINYL PLANK PRIOR TO INSTALLATION, IT MUST ALSO BE AT NRC(NORMAL ROOM CONDITIONS).

NRC (NORMAL ROOM CONDITIONS) MUST BE CONSISTENTLY MAINTAINED AT:

- ROOM TEMPERATURE BETWEEN 64-84 DEGREES FAHRENHEIT
- SURFACE TEMPERATURE BETWEEN 64-84 DEGREES FAHRENHEIT
- AMBIENT RH (RELATIVE HUMIDITY) BETWEEN 25%-60%
- FLOORING MATERIAL MUST BE MAINTAINED BETWEEN 64-84 DEGREES FAHRENHEIT

### 6) SUBFLOOR FLATNESS REQUIREMENTS

#### SUBFLOOR FLATNESS:

- SUBFLOOR MUST BE FLAT, WITH NO UNDULATION EXCEEDING 5/64" UNDULATION IN 6.56 LINEAR FEET. GRIND HIGH SPOTS DOWN AND/OR FILL LOW SPOTS WITH A QUALITY CEMENT PATCHING COMPOUND. ALLOW PATCH TO COMPLETELY DRY PRIOR TO INSTALLATION. FOLLOW PATCH MANUFACTURERS INSTALLATION GUIDELINES.
- FOLLOW ALL LOCAL BUILDING REGULATIONS AND OSHA PROCEDURES WHEN GRINDING. SOME SUBSTRATES MIGHT CONTAIN HARMFUL CONTAMINATES; SUCH AS SILICA SAND OR ASBESTOS. IT IS CRITICAL THAT YOU DETERMINE PRIOR TO GRINDING IF THERE ARE ANY HARMFUL CONTAMINANTS IN THE SUBFLOOR.

**WARNING:** FOLLOW THE RESILIENT FLOOR COVERING INSTITUTE (RFCI) (RFCI.COM) RECOMMENDED PRACTICES WHENEVER GRINDING A SUBSTRATE, EXISTING FLOORING, OR ADHESIVE RESIDUE. THESE SURFACES MAY CONTAIN ASBESTOS OR OTHER HARMFUL CONTAMINATES.

## **7) SUBFLOOR CONSTRUCTION REQUIREMENTS**

### **SUBFLOOR CONSTRUCTION MUST MEET ALL LOCAL AND FEDERAL BUILDING CODES:**

SUBFLOORS MUST BE SOUNDLY CONSTRUCTED ( JOIST MINIMUM 16" ON CENTER), TO ELIMINATE VERTICAL MOVEMENT. SUBFLOORS MUST BE FLAT, NOT TO EXCEED UNDULATIONS EXCEEDING 63/800" UNDULATION IN 6.56 LINEAR FEET. IT IS THE FLOOR COVERING INSTALLERS RESPONSIBILITY TO ENSURE THAT SUBFLOOR CONDITIONS ARE SUITABLE.

#### **APPROVED SUBFLOORS:**

- CONCRETE, PROPERLY PREPARED CONCRETE, CEMENT PATCH AND LEVELING COMPOUNDS (MINIMUM 3500 PSI). MUST NOT EXCEED 55% RH (ASTM F2170) AND MUST NOT EXCEED 10LB MVER (ASTM F1869). PH LEVELS MUST BE BETWEEN 5-9.
- GYPSUM, PROPERLY PREPARED GYPSUM (MINIMUM 3500 PSI). MUST BE DRY BASED ON GYPSUM AND ADHESIVE MANUFACTURER STANDARDS, MAXIMUM 55% RH (ASTM F2170).
- WOOD, PROPERLY PREPARED WOOD (UNDERLAYMENT GRADE PLYWOOD, OSB & OFB) MUST BE A MINIMUM 1" THICK (CAN BE 3/4" THICK WITH A 1/4" PLYWOOD UNDERLAYMENT). SUBFLOOR MUST HAVE A MINIM 18" CLEARANCE BETWEEN THE BOTTOM OF THE JOIST AND THE GROUND. GROUND MUST BE COVERED 100% WITH 6-MIL POLY FILM.
- EXISTING FLOOR COVERING THAT IS FIRMLY BONDED TO THE SUBSTRATE; DENSE NOT CUSHIONED, AND ONLY ONE LAYER THICK.

#### **NON-APPROVED SUBFLOORS:**

- SLEEPER TYPE FLOOR SYSTEMS.
- PLYWOOD INSTALLED DIRECTLY OVER A CONCRETE SLAB.
- SOFT PLYWOOD, LUAN, PRESSURE TREATED, OR PLYWOOD NOT APPROVED AS "UNDERLAYMENT GRADE" CERTIFIED BY THE PLYWOOD ASSOCIATION.
- MASONITE OR HARDBOARD.
- CONTAMINATED SURFACES: ABATEMENT CHEMICALS, PAINT, OIL, MOLD, MILDEW, GREASE OR ANY CONTAINMENTS.
- STRIP PLANK WOOD FLOORING.
- UNEVEN (EXCEED 63/800" IN 6.56 LINEAR FEET) OR UNSTABLE SUBSTRATES.

**ON GRADE AND BELOW GRADE SUBSTRATES:** BELOW GRADE SUBSTRATES REQUIRE A 6MIL POLYETHYLENE FILM BE APPLIED TO THE SUBSTRATE OR A PERMANENT MOISTURE MITIGATION PRODUCT MUST BE APPLIED. ON GRADE SUBSTRATES WHERE MOISTURE EXCEEDS 55% RH MUST HAVE A 6MIL POLYETHYLENE FILM MUST BE APPLIED.

**IMPORTANT:** FOR ANY SUBSTRATES NOT MENTIONED ABOVE CHECK WITH THE MANUFACTURER BEFORE PROCEEDING WITH THE INSTALLATION.

## **8) RADIANT HEATED FLOORS**

### **RADIANT HEATED SUBSTRATES:**

INSTALLATION OVER HYDRONIC (WATER) RADIANT HEAT SYSTEMS IS ACCEPTABLE, PROVIDING THE SUBSTRATE NEVER EXCEEDS 81 DEGREES FAHRENHEIT. PRIOR TO INSTALLING OVER NEWLY CONSTRUCTED RADIANT HEAT SYSTEMS, OPERATE THE SYSTEM AT MAXIMUM CAPACITY TO FORCE ANY RESIDUAL MOISTURE FROM THE CEMENTITIOUS TOPPING OF THE RADIANT HEAT SYSTEM. SYSTEM MUST BE OPERATIONAL FOR A MINIMUM OF TWO WEEKS PRIOR TO INSTALLATION.

A SUBSTRATE TEMPERATURE BETWEEN 64-84 DEGREES FAHRENHEIT MUST BE ACHIEVED FIVE DAYS PRIOR TO, MAINTAINED DURING, AND FOR 48 HOURS AFTER THE INSTALLATION. IT IS RECOMMENDED THAT THE RADIANT HEAT BE APPLIED IN A GRADUAL MANNER AFTER INSTALLING THE LUXURY VINYL FLOORING(AFTER INSTALLATION, THE TEMPERATURE CAN BE RAISED GRADUALLY(5°F PER HOUR) TO A MAXIMUM OPERATION TEMPERATURE OF 84°F. AN IN-FLOOR THERMOSTAT IS RECOMMENDED TO AVOID OVERHEATING.REFER TO THE RADIANT HEAT SYSTEM MANUFACTURER'S RECOMMENDATIONS FOR ADDITIONAL GUIDANCE.

**IMPORTANT:** DUE TO THE SPEED OF SUDDEN TEMPERATURE CHANGES, WHICH HAS POTENTIAL TO NEGATIVELY AFFECT VINYL FLOORING CONSTRUCTION, IT IS NOT RECOMMENDED TO INSTALL OVER ELECTRICAL RADIANT HEATING SYSTEMS. THIS WILL NOT BE COVERED BY THE MANUFACTURER'S WARRANTY. **ONLY RADIANT HEATING SYSTEMS USING WATER ARE ACCEPTABLE.** INSTALLATION OVER ELECTRICAL RADIANT HEATING SYSTEMS WILL NOT BE COVERED BY THE MANUFACTURER'S WARRANTY. DO NOT USE THIS PRODUCT OVER ELECTRIC COIL HEATER.

## 9) LAYOUT

- IT IS BEST TO LAY FLOORING PARALLEL TO LIGHT SOURCE (SUCH AS A WINDOW). BUT THE PREMISE IS THAT WHEN INSTALLING THE LENGTH SIDE OF THE PLANK MUST BE PARALLEL TO THE LENGTH SIDE OF THE ROOM OR THE AREA.
- DETERMINE THE CENTER OF THE ROOM BY MARKING THE CENTER OF EACH END WALL. SNAP A CHALK LINE BETWEEN THESE TWO POINTS.
- DRY LAY ROWS TO WALL, IF THE PLANK TO THE LONG WALL WILL BE LESS THAN 2" WIDTH ADJUST THE CENTER LINE TO MAKE THE LONG WALL PLANK OVER 2". THE GOAL IS TO HAVE PLANKS NEXT TO THE WALL TO BE A MINIMUM OF 2". BALANCE THE CUTS IN THE ROOM.
- STAGGER END JOINTS BY A MINIMUM OF 12" ON A RANDOM BASIS.

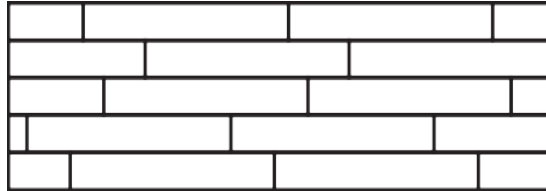

**Staggered Joint Design**

## 10) EXPANSION SPACE AND TRANSITION TRIM

### EXPANSION SPACE:

FLOORING EXPANDS AND CONTRACTS WITH NORMAL CLIMATE CHANGES. THIS PRODUCT MUST BE ALLOWED TO FREELY FLOAT, TO EXPAND AND CONTRACT MONOLITHICALLY.

- AT ALL VERTICAL SURFACES IN AREAS UP TO 441.32SF , A 1/4" EXPANSION SPACE IS REQUIRED(REFERENCE TEMPERATURE DIFFERENCE IS 59 DEGREES FAHRENHEIT.TEMPERATURE DIFFERENCE EQUALS TO INSTALLATION TEMPERATURE MINUS THE RATIO VALUE OF HIGHEST TEMPERATURE AND LOWEST TEMPERATURE IN USAGE.)
- UNDERCUT DOOR JAMBS AND OTHER VERTICAL SURFACES TO ALLOW FLOORING TO FREELY FIT UNDERNEATH.WITH A FLOATING FLOOR YOU MUST ALWAYS ENSURE YOU LEAVE A 1/4" GAP BETWEEN WALLS AND FIXTURES SUCH AS PIPES AND PILLARS, STAIRS, ETC. THESE GAPS WILL BE COVERED WITH TRIM MOLDINGS AFTER THE FLOOR IS INSTALLED. TIP: WHEN INSTALLING AROUND PIPES, DRILL THE HOLES 3/4" LARGER THAN THE DIAMETER OF THE PIPES. FOR FLOOR SURFACE EXCEEDING 40FT ADDITIONAL EXPANSION OF 1/4" IS NEEDED AROUND ENTIRE ROOM.
- AT VERTICAL SURFACES THAT WILL NOT BE RECEIVING WALL BASE OR OTHER EXPANSION TRIM (SUCH AS SLIDING GLASS DOORS); ALLOW A MINIMUM 1/4 " EXPANSION GAP AND CAULK GAP WITH A FLEXIBLE CAULKING (SILICONE).
- DO NOT FIT FLOORING FULL OR UNDER COMPRESSION.

### EXPANSION TRANSITION TRIM:

TRANSITION TRIM MUST BE USED IN THE FOLLOWING:

- IN AREAS EXCEEDING 441.32SF OR LONGITUDINAL LENGTH IS UP TO19.68' AND TO ROOMS WHICH DO NOT JOIN SYMMETRICALLY.
- BETWEEN AREAS OF UNEVEN HEATING, WHERE ONE AREAS TEMPERATURE MIGHT BE MAINTAINED DIFFERENTLY THAN AN ADJOINING AREA.
- AT DOORWAYS AND SLIDING GLASS DOORWAYS, USE AN END CAP SQUARE EDGE TRANSITION.
- USE TRANSITION TRIM IN ADJOINING AREAS OF IRREGULAR SHAPE, SUCH AS BUT NOT LIMITED TO: L-SHAPE, U-SHAPE, T-SHAPE.
- DO NOT NAIL OR STAPLE TRIM SO THAT IT RESTRICTS FLOOR MOVEMENT SUCH AS NAILING INTO FLOOR OR TOO TIGHTLY AGAINST FLOOR SURFACE.

## 11) TRIM



**End Cap**

Use at sliding glass doors, entry doors, fireplaces, carpet, etc .



**T-Mold**

Use between two products close in height.



**Reducer**

Use when transitioning to hard surface.



**Stair Nose**

Use at stair nose.



**Quarter Round**

Use at wall base to extend coverage.

Trim profiles are approximate and may change without notice. Trims are coordinating, color or graining may not be exact.

- IF EXISTING BASEBOARD MOLDING IS DIFFICULT TO REMOVE, QUARTER ROUND MOLDING WILL BE REQUIRED TO COVER THE EXPANSION SPACE NEED BETWEEN FLOORING AND BASEBOARD.

## 12) INSTALLING ON STAIRS

- WHEN INSTALLING ON STAIRS, A STAIR NOSING MUST BE USED.
- WHEN ADHERING FLOORING TO STAIRS USE A PERMANENT BONDING ADHESIVE (URETHANE ADHESIVE OR SOLVENT-FREE CONSTRUCTION ADHESIVE).
- THE ATTACHED PAD MUST BE REMOVED.

## 13) INSTALLATION INSTRUCTIONS

### STARTING YOUR INSTALLATION

WORK FROM SEVERAL OPEN BOXES OF FLOORING AND "DRY LAY" THE FLOOR BEFORE PERMANENTLY LAYING THE FLOOR. THIS WILL ALLOW YOU TO SELECT THE VARYING GRAINS & COLORS AND TO ARRANGE THEM IN A HARMONIOUS PATTERN. REMEMBER, IT IS THE INSTALLERS' RESPONSIBILITY TO DETERMINE THE EXPECTATIONS OF WHAT THE FINISHED FLOOR WILL LOOK LIKE WITH THE END USER FIRST AND THEN TO CULL OUT PIECES THAT DO NOT MEET THOSE EXPECTATIONS.

INSPECTION: PRIOR TO INSTALLATION, INSPECT PLANKS IN DAYLIGHT FOR VISIBLE FAULTS/DAMAGE. CHECK IF SUBFLOOR/SITE CONDITIONS COMPLY WITH THE SPECIFICATIONS DESCRIBED IN THESE INSTRUCTIONS. IF YOU ARE NOT SATISFIED DO NOT INSTALL, AND CONTACT YOUR SUPPLIER.

INSPECT EACH INDIVIDUAL PLANK ONE BY ONE BEFORE INSTALLATION. NO CLAIMS ON SURFACE DEFECTS WILL BE ACCEPTED AFTER INSTALLATION.

ENSURE THE TONGUES ON LONG EDGE JOINT AND END JOINTS ARE FACING THE WALL. BEGIN INSTALLATION NEXT TO AN OUTSIDE WALL. THIS IS USUALLY THE STRAIGHTEST AND BEST REFERENCE FOR ESTABLISHING A STRAIGHT WORKING LINE. ESTABLISH THIS LINE BY MEASURING AN EQUAL DISTANCE FROM THE WALL AT BOTH ENDS AND SNAPPING A CHALK LINE. THE DISTANCE YOU MEASURE FROM THE WALL SHOULD BE THE WIDTH OF A PLANK. YOU MAY NEED TO SCRIBE CUT THE FIRST ROW OF PLANKS TO MATCH THE WALL IN ORDER TO MAKE A STRAIGHT WORKING LINE IF THE WALL IS OUT OF STRAIGHT.

YOU MAY WANT TO POSITION A FEW ROWS BEFORE STARTING INSTALLATION TO CONFIRM YOUR LAYOUT DECISION AND WORKING LINE. WHEN LAYING FLOORING, STAGGER END JOINTS FROM ROW TO ROW BY AT LEAST 12". WHEN CUTTING THE LAST PLANK IN A ROW TO FIT, YOU CAN USE THE CUT-OFF END TO BEGIN THE NEXT ROW. IF CUT-OFF END IS 12" IN LENGTH OR LESS, DISCARD IT AND INSTEAD CUT A NEW PLANK AT A RANDOM LENGTH AND USE IT TO START THE NEXT ROW. ALWAYS BEGIN EACH ROW FROM THE SAME SIDE OF THE ROOM. WHEN NEAR A WALL, YOU CAN USE A PRY BAR TO PRY CLOSE THE SIDE AND END JOINTS.

BEFORE LAYING: MEASURE THE ROOM AT RIGHT ANGLE TO THE DIRECTION OF THE PLANKS. FOR BEST VISUAL EFFECT, PLANKS IN THE FINAL ROW SHOULD BE AT LEAST 2 INCHES WIDE (HALF WIDTH OF PLANK MINIMUM). FOR THIS PURPOSE, PLANKS IN THE FIRST ROW CAN BE CUT TO SMALLER SIZE. SHUFFLE PLANKS IN ORDER TO OBTAIN A PLEASANT BLEND OF SHADES. LAY PLANKS PREFERABLY FOLLOWING THE DIRECTION OF THE MAIN SOURCE OF LIGHT. WE RECOMMEND LAYING ON WOODEN FLOORS CROSSWAYS TO THE EXISTING FLOORBOARD. PLANKS MUST NOT BE NAILED OR SCREWED TO THE SUBFLOOR. BASE BOARDS AND MOLDING MUST NOT BE FIXED IN A WAY WHICH RESTRICTS THE MOVEMENT OF THE FLOOR.

**IMPORTANT** - DO NOT RESTRICT MOVEMENT OF THE FLOOR BY PLACING HEAVY OBJECTS LIKE KITCHEN ISLANDS OR CABINETS ONTO THE FLOORING.

### INSTALLING GUIDE

1. YOU WILL NEED TO REMOVE THE TONGUE ON THE SIDE OF THE PANELS THAT FACE THE WALL. THIS IS TO ENSURE THAT THE DECORATIVE SURFACE OF THE FLOOR IS WELL UNDER THE FINISHED TRIM WHEN INSTALLED. USE A UTILITY KNIFE TO SCORE THROUGH THE TONGUE SEVERAL TIMES UNTIL IT EASILY SNAPS OFF. START IN A CORNER BY PLACING THE FIRST PANEL WITH THE TRIMMED SIDE FACING THE WALL. USE SPACERS ALONG EACH WALL TO MAINTAIN AN EXPANSION SPACE OF 6-15MM BETWEEN THE WALL AND THE FLOORING. ADJUST ROW SO END CUT IS NOT LESS THAN 12". (F1) **NOTE:** THIS PRODUCT NEEDS ROOM TO EXPAND AND CONTRACT. AT NO POINT SHOULD YOU ATTACH THE FLOOR TO ANY SURFACE. **DIAGRAM 1.**
2. TO ATTACH THE SECOND PLANK, INSERT THE END TONGUE INTO THE END GROOVE OF THE VERY FIRST PLANK AT AN ANGLE OF APPROX. 15-20 DEGREES. WHEN LOWERED, THE PLANK WILL CLICK INTO PLACE. LINE UP EDGES AND CORNERS CAREFULLY. THE PLANKS SHOULD BE FLAT TO THE FLOOR. **DIAGRAM 2.**
3. CONTINUE CONNECTING THE FIRST ROW UNTIL YOU REACH THE LAST FULL PLANK. FIT THE LAST PANEL BY ROTATING THE PANEL 180° WITH THE PATTERN SIDE UPWARD, PLACE BESIDE ROW, MARK AND SAW OFF EXCESS. ATTACH AS DESCRIBED ABOVE. WHEN USING A HANDSAW, CUT ON THE DECORATIVE SURFACE. IF YOU USE A JIG OR CIRCULAR SAW, CUT WITH THE DECORATIVE SIDE DOWN TO AVOID CHIPPING. USE LEFTOVER PLANK FROM FIRST ROW AS STARTER FOR SECOND ROW. THERE MUST BE AT LEAST 12 INCHES BETWEEN PLANK END JOINTS ON ADJACENT ROWS. **DIAGRAM 3.**
4. BEGIN THE NEXT ROW WITH THE OFF CUT PIECE FROM THE PREVIOUS ROW TO STAGGER THE PATTERN. PIECES SHOULD BE A MINIMUM OF 20 CM (8 IN) LONG AND JOINT OFFSET SHOULD BE AT LEAST 30 CM (12 IN). THIS MAY REQUIRE CUTTING A PLANK TO START A ROW DEPENDING ON THE SIZE OF THE ROOM. **DIAGRAM 4.**
5. TO START YOUR SECOND ROW, LAY YOUR FIRST PLANK ON THE SUBFLOOR. TAKE YOUR SECOND PLANK, INSERT THE END TONGUE INTO THE END GROOVE OF THE FIRST PLANK AT AN ANGLE OF APPROX. 15-20 DEGREES. WHEN

LOWERED, THE PLANK WILL CLICK INTO PLACE WITH LIGHT PRESSURE. THE PLANKS SHOULD BE FLAT TO THE FLOOR. MAKE SURE GAPS ARE AS SMALL AS POSSIBLE. CONTINUE ASSEMBLING THE PLANKS THIS WAY UNTIL YOU HAVE YOUR SECOND ROW COMPLETE.

6. TO ATTACH THE SECOND ROW TO THE FIRST ROW, TILT AND PUSH THE SIDE TONGUE INTO THE SIDE GROOVE OF THE FIRST PANEL AT AN ANGLE OF APPROX. 15-20 DEGREES. LOWER AND CLICK INTO PLACE LINING THE EDGES UP CAREFULLY. CONTINUE LAYING REMAINING PLANKS IN THIS MANNER. **DIAGRAM 5.**
7. TO FIT THE LAST ROW, LAY A PLANK ON TOP OF THE PREVIOUS ROW. WITH THE TONGUE TO THE WALL, LAY ANOTHER PLANK UPSIDE DOWN ON THE ONE TO BE MEASURED AND USE IT AS A RULER. DON'T FORGET TO ALLOW ROOM FOR SPACERS. CUT THE PLANK AND ATTACH INTO POSITION. **DIAGRAM 6.**
8. DOOR FRAMES AND HEATING VENTS ALSO REQUIRE EXPANSION ROOM. FIRST CUT THE PLANK TO THE CORRECT LENGTH. THEN PLACE THE CUT PLANK NEXT TO ITS ACTUAL POSITION AND USE A RULER TO MEASURE THE AREAS TO BE CUT OUT AND MARK THEM. CUT OUT THE MARKED POINTS ALLOWING THE NECESSARY EXPANSION DISTANCE ON EACH SIDE. T-MOLDING IS STRONGLY SUGGESTED IN ALL DOORWAYS. **DIAGRAM 7.**  
 YOU CAN TRIM DOOR FRAMES BY TURNING A PLANK UPSIDE DOWN AND USING A HANDSAW TO CUT AWAY THE NECESSARY HEIGHT SO THAT PLANKS SLIDE EASILY UNDER THE FRAMES. **DIAGRAM 8.**  
 NOTE: SILICONE CALKING SHOULD BE APPLIED ON TOP OF THE FLOORING SUCH AS DOOR FRAMES, PIPES, ETC. AND NOT IN THE EXPANSION GAP.

### COMPLETION

1. PROTECT ALL EXPOSED EDGES OF THE FLOORING BY INSTALLING WALL MOLDING AND/OR TRANSITION STRIPS. MAKE SURE THAT NO PLANK WILL BE SECURED IN ANY WAY TO THE SUBFLOOR.
2. FOR WET AREAS SUCH AS BATHROOMS CAULK THE PERIMETER OF THE FLOOR WITH A FLEXIBLE SILICONE CAULK.
3. PROTECT THE FINISHED FLOORING FROM EXPOSURE TO DIRECT SUNLIGHT TO REDUCE FADING AND THERMAL EXPANSION.

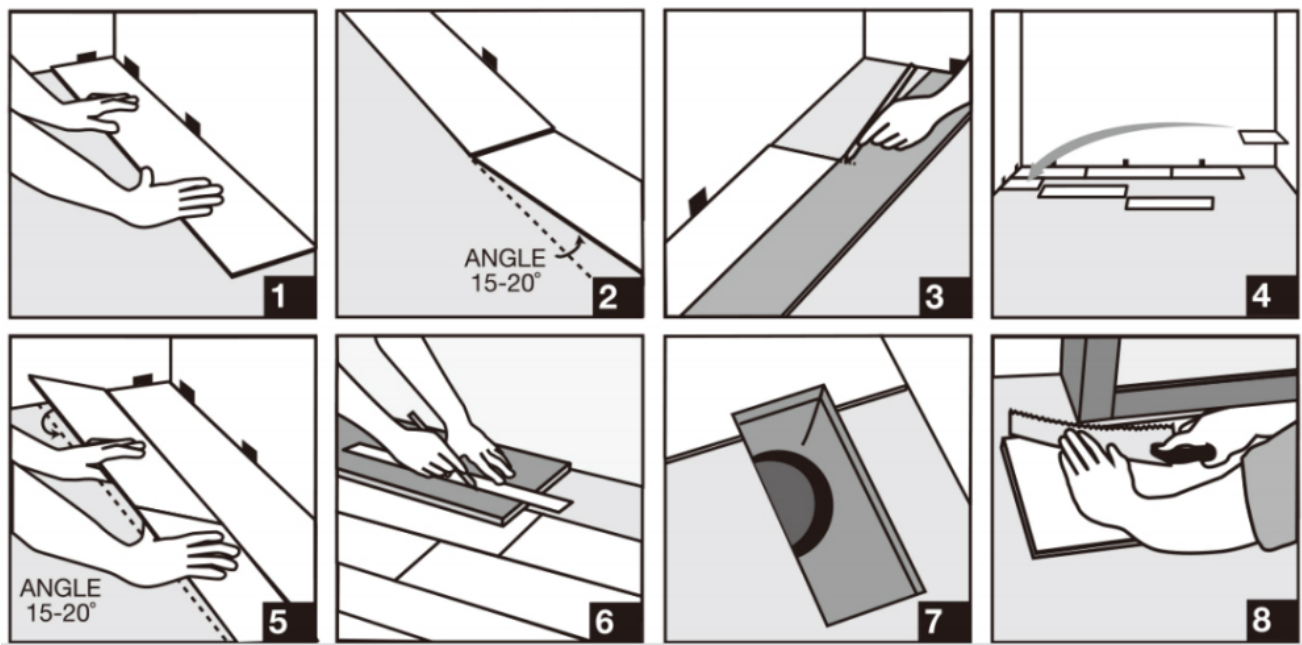

### 14) POST INSTALLATION

#### FLOOR PROTECTION:

- IF OTHER TRADES ARE WORKING IN THE INSTALLATION AREA, PROTECT FLOORING WITH AN APPROVED BREATHABLE FLOOR PROTECTION MATERIAL SUCH AS A BUILDER BOARD OR REINFORCED 60LB KRAFT PAPER.
- ALWAYS USE CHAIR PADS UNDER ROLLING CASTER CHAIRS AND CHAIR LEG PROTECTORS, MINIMUM OF 1-1/2" DIAMETER, UNDER FURNITURE LEGS.

### 15) MAINTENANCE

#### INITIAL MAINTENANCE

- ALWAYS USE A NEUTRAL PH CLEANER, SUCH AS WF TAYLOR FRESH FLOORS. DO NOT USE ABRASIVE CLEANERS, BLEACH OR WAX TO MAINTAIN THE FLOOR.
- ALLOW FLOORING TO DRY COMPLETELY PRIOR TO FOOT TRAFFIC.

#### DAILY & WEEKLY MAINTENANCE

- SWEEP, DUST MOP, OR VACUUM THE FLOOR AS NEEDED TO REMOVE LOOSE DIRT AND GRIT. DO NOT USE A VACUUM



WITH BRISTLES OR A BEATER BAR.

- RECOMMEND CLEANING LIQUID SPILLS IMMEDIATELY.
- DAMP MOP (DO NOT FLOOD FLOOR) AS NEEDED AND USE CLEANERS RECOMMENDED WITH NO-WAX OR OIL

**PREVENTATIVE MAINTENANCE**

- CHAIR PADS ARE REQUIRED UNDER ROLLER CASTOR CHAIRS.
- FURNITURE LEG PROTECTORS, MINIMUM 1.5" DIAMETER, ARE REQUIRED UNDER ALL FURNITURE LEGS.
- DO NOT DRAG OR SLIDE HEAVY OBJECTS ACROSS THE FLOOR.
- NEVER APPLY RUBBER MATS DIRECTLY ON TOP OF VINYL FLOORING.
- PLACE WALK OFF MATS OUTSIDE ENTRY DOORS TO PREVENT DIRT AND SAND FROM ENTERING INTO THE INSTALLATION.
- PROTECT FLOORING FROM DIRECT SUNLIGHT WITH WINDOW AND GLASS DOOR COVERINGS TO PREVENT FADING. CLOSE BLINDS OR DRAPES DURING PEAK SUN LIGHT HOURS
- ANY ADDITIONAL FLOOR FINISHES ARE NOT REQUIRED AND NOT APPROVED. THE APPLICATION OF ANY ADDITIONAL FLOOR FINISHES WILL VOID ALL WARRANTIES.